

- NOTES:**
1. PLACE MULCH BLANKET PARALLEL TO FLOW AND ANCHOR SECURELY.
 2. WHEN BLANKETS ARE USED IN FLOWING DITCH, BLANKETS SHOULD NOT OVERLAP IN DITCH CENTER PARALLEL TO FLOW.
 3. STAPLES INSTALLED/SECURED ACCORDING TO MANUFACTURER'S SPECIFICATIONS.
 4. WHERE POSSIBLE, CONSTRUCT WITH BIODEGRADABLE MATERIAL.

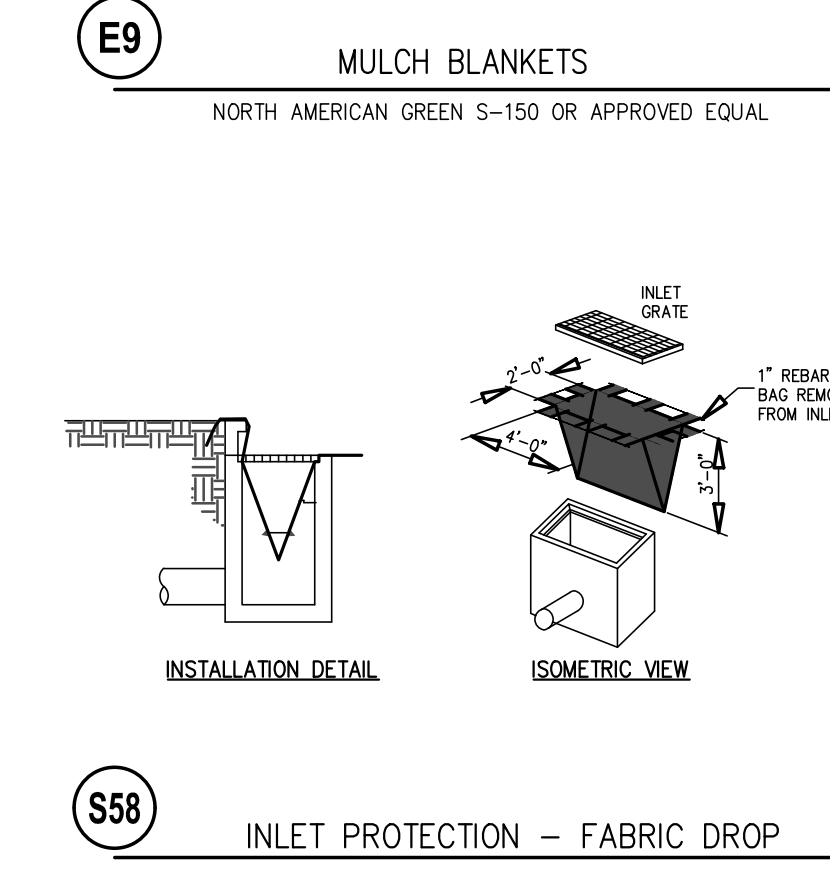

PROPOSED CONSTRUCTION SCHEDULE

ACTIVITY	2011			
	MAR	APR	MAY	JUN
TEMPORARY EROSION CONTROLS				→
CLEARING, GRUBBING, & TOPSOIL STRIPPING	→			
MASS GRADING & WALL CONSTRUCTION		→		
TOPSOIL RESTORATION & SEEDING				→

S.E.S.C. LEGEND
MICHIGAN UNIFIED KEYING SYSTEM

Key	Description	Symbol	Notes
E8	PERMANENT SEEDING		Stabilization method utilized on sites where earth change has been completed (final grading attained).
E9	MULCH BLANKETS		On exposed slopes, newly seeded areas, new ditch bottoms, or areas subject to erosion.
S51	SILT FENCE		Use adjacent to critical areas, to prevent sediment laden sheet flow from entering these areas.
S58	INLET PROTECTION FABRIC DROP		Use at storm water inlets, especially at construction sites.

○ DENOTES TEMPORARY □ DENOTES PERMANENT

HOLLAND ENGINEERING
ENGINEERING | SURVEYING | PIPELINE SERVICES
220 Hoover Boulevard, Suite 2
Holland, Michigan 49423-3766
www.hollandengineering.com
T 616-392-5938 F 616-392-2116

The Surveyor's/Engineer's liability for any and all claims, including but not limited to those arising out of negligence, gross negligence, or misrepresentation shall be deemed limited to an amount no greater than the services fee.

SUBCONSULTANT INFORMATION

SOUTH HAVEN AMERICAN LEGION
ATTN: MR. JIM MONTGOMERY
129 MICHIGAN AVENUE
SOUTH HAVEN, MI 49090

RETAINING WALLS
129 MICHIGAN STREET
SOUTH HAVEN, MICHIGAN
PART OF THE NW 1/4, SEC 10, T15N, R17W
VILLAGE OF SOUTH HAVEN, VAN BUREN CO, MI

Date	Description	No.
06/24/2010	ADDED RETAINING WALL DETAILS	D
06/29/2010	INCLUDE REMOVAL OF EXISTING WALL	E
08/03/2010	ADD CROSS SECTIONS	F
08/12/2010	REVISE WALL LAYOUT	G
09/15/2010	PERMITS	H
10/29/2010	EDITS	I
12/27/2010	REVISED WALL EXTENSION	J

Plans are preliminary & incomplete until ISSUED FOR CONSTRUCTION.

Project Manager: RYAN T. YSSELDYKE, P.E.
Vertical Datum: NAVD 88 | Horiz Datum: LOCAL
Checked by: JEREMY D. BORGMAN
Checked by: DJL | Date: 00/00/00
Survey: DJL | Date: 00/00/00
Civil: BWL | Date: 00/00/00
Struc: RTY | Date: 00/00/00
L. A. BEZ | Date: 00/00/00
HEI Project Number: 10-05-014
Sheet Title: SECS, GRADING, & STORM PLAN
Sheet No.: C-201